

190
Bowery

34,000 SF Move-In Ready
Entire Building Available



Full Building Available at the Corner of Bowery and Spring Street

Exclusive Private Entry on Bowery

Historic Building with Creative
Office Space

Large, Operable Windows with
Abundant Natural Light and
High Ceilings

Move-In Ready

Interconnecting Stairway and
Two Elevators

Kitchens, Pantries, and Conference
Rooms on Each Floor

Rooftop Views and Watertank
Mural by Shepard Fairey



















PLEASE DO NOT
LEAVE DIRTY DISHES
IN THE SINK







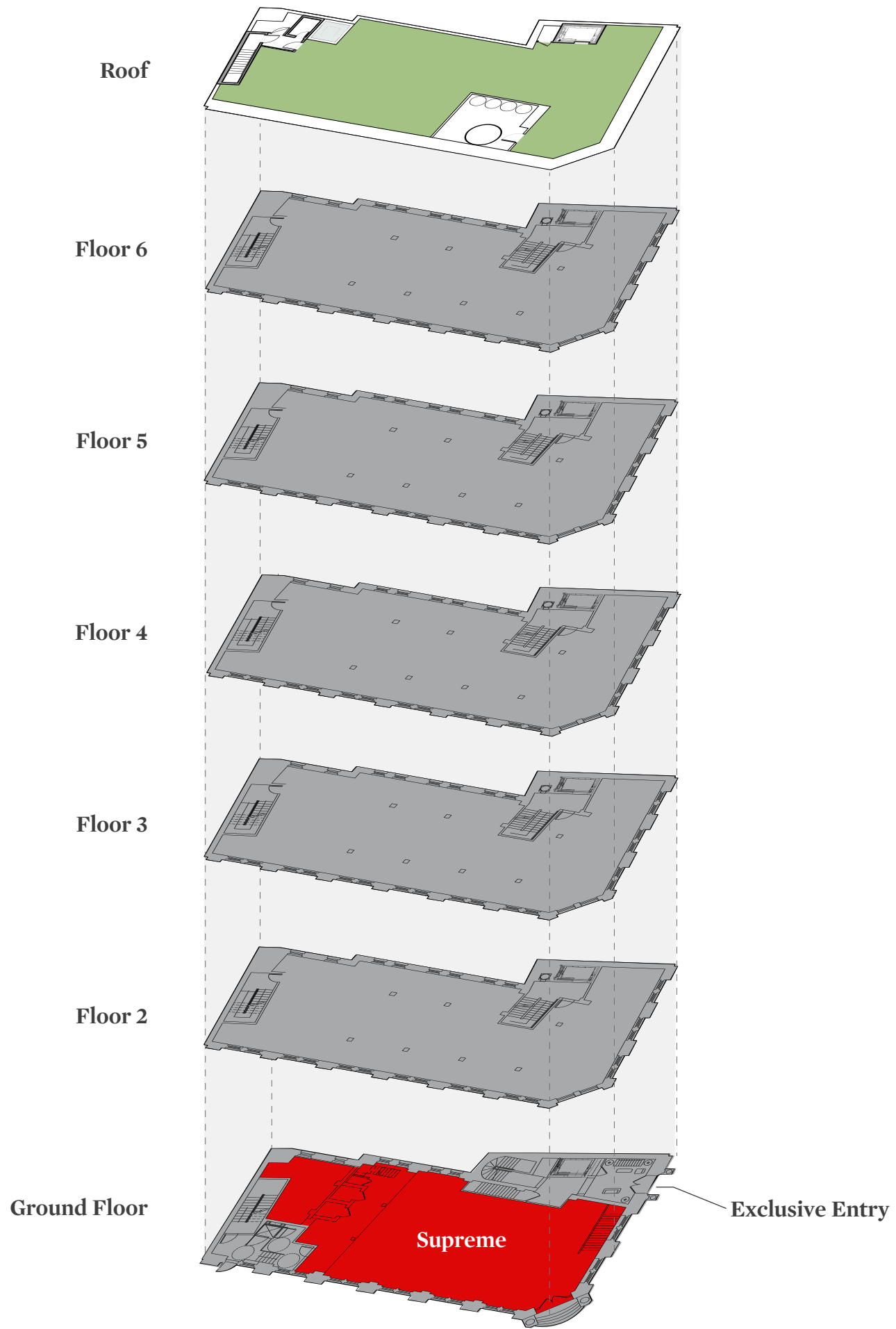

Ground Floor
 905 SF
 19'-3" Ceiling

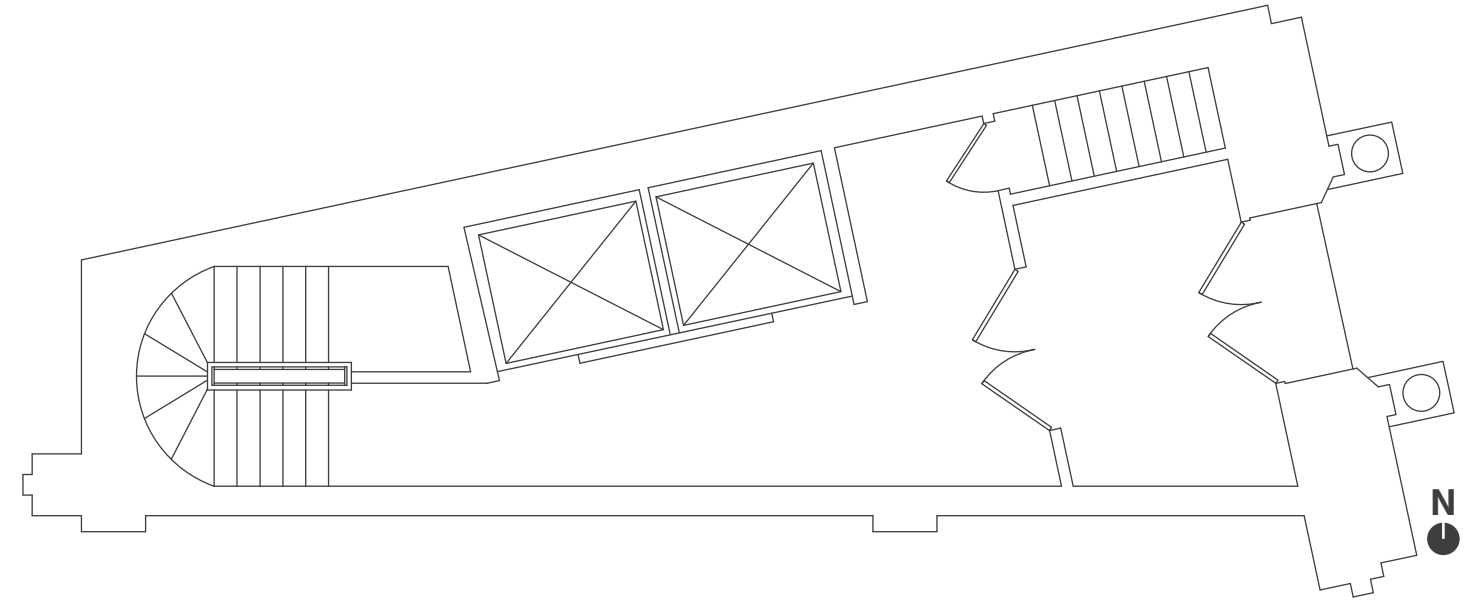

Mezzanine
 905 SF
 7'-8" Ceiling

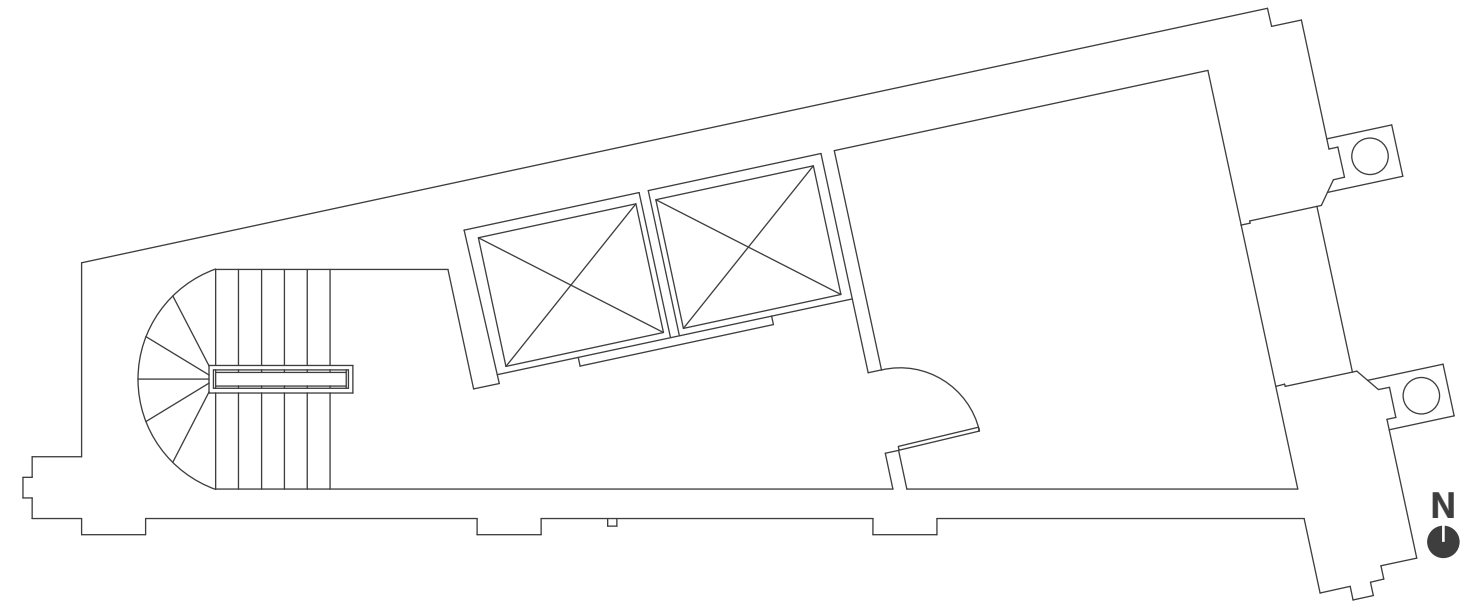

Floor 2
6,401 SF
13'-9" Ceiling

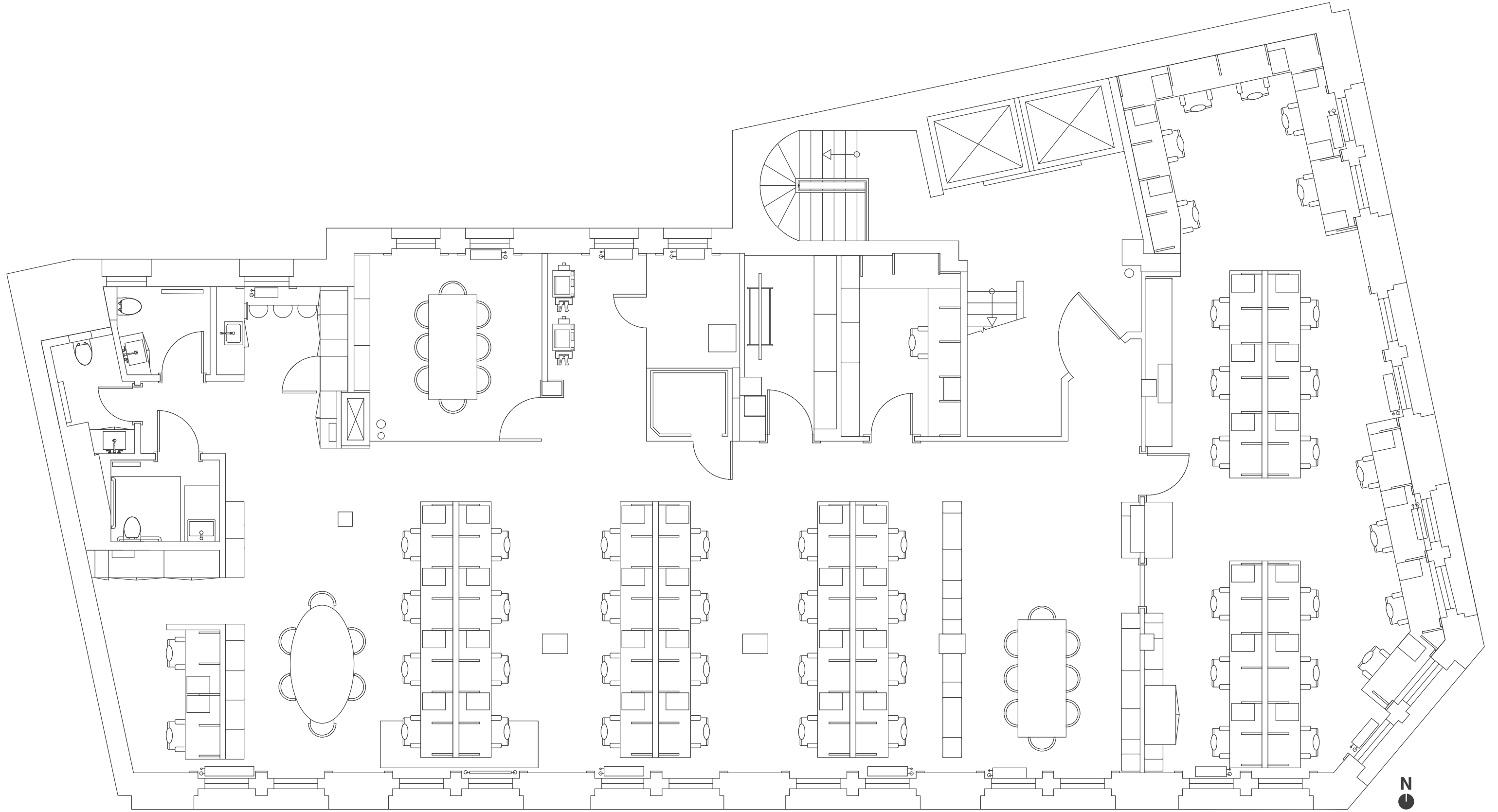

Floor 3
6,255 SF
12' Ceiling

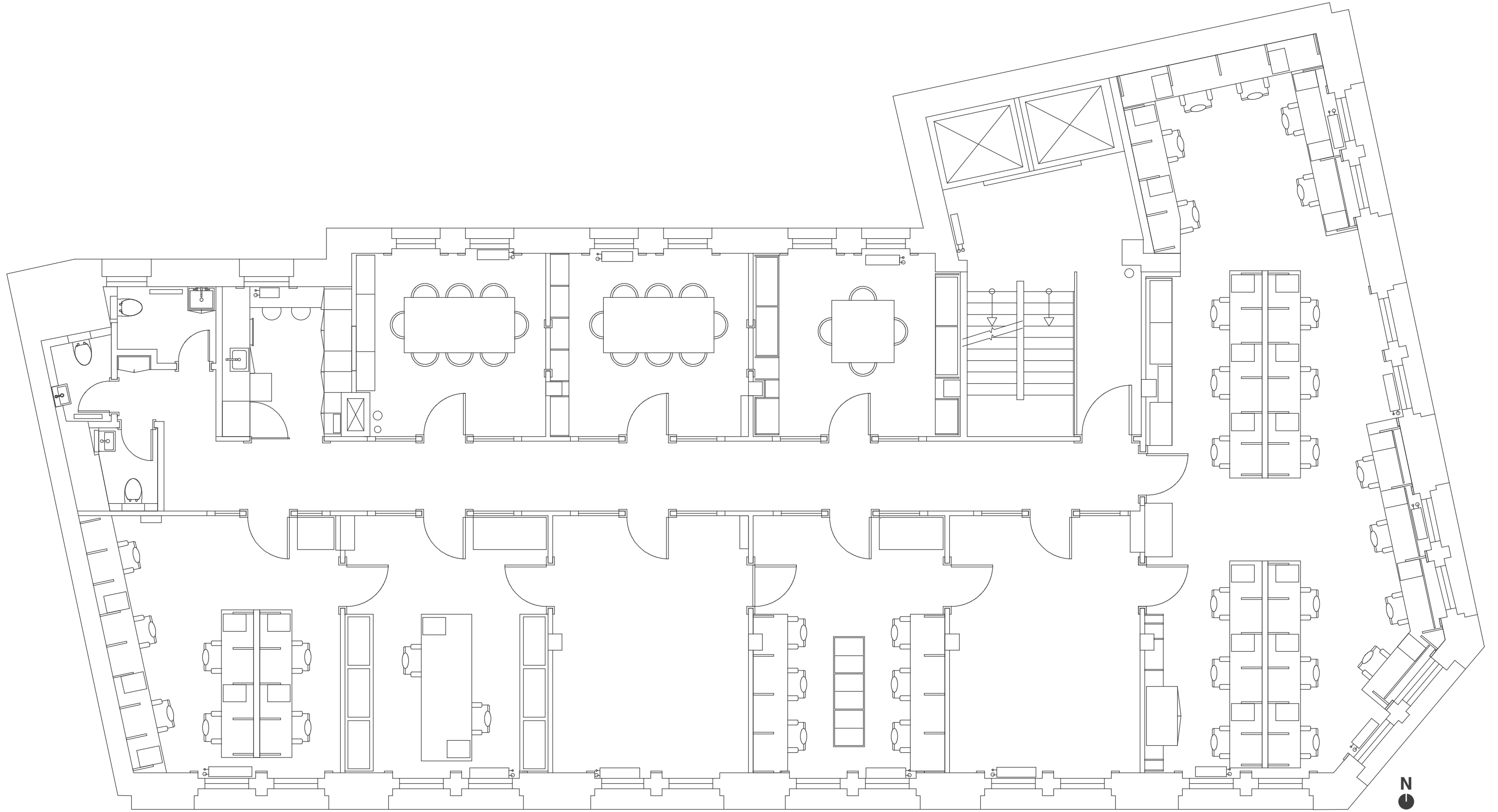

Floor 4
6,255 SF
12' Ceiling

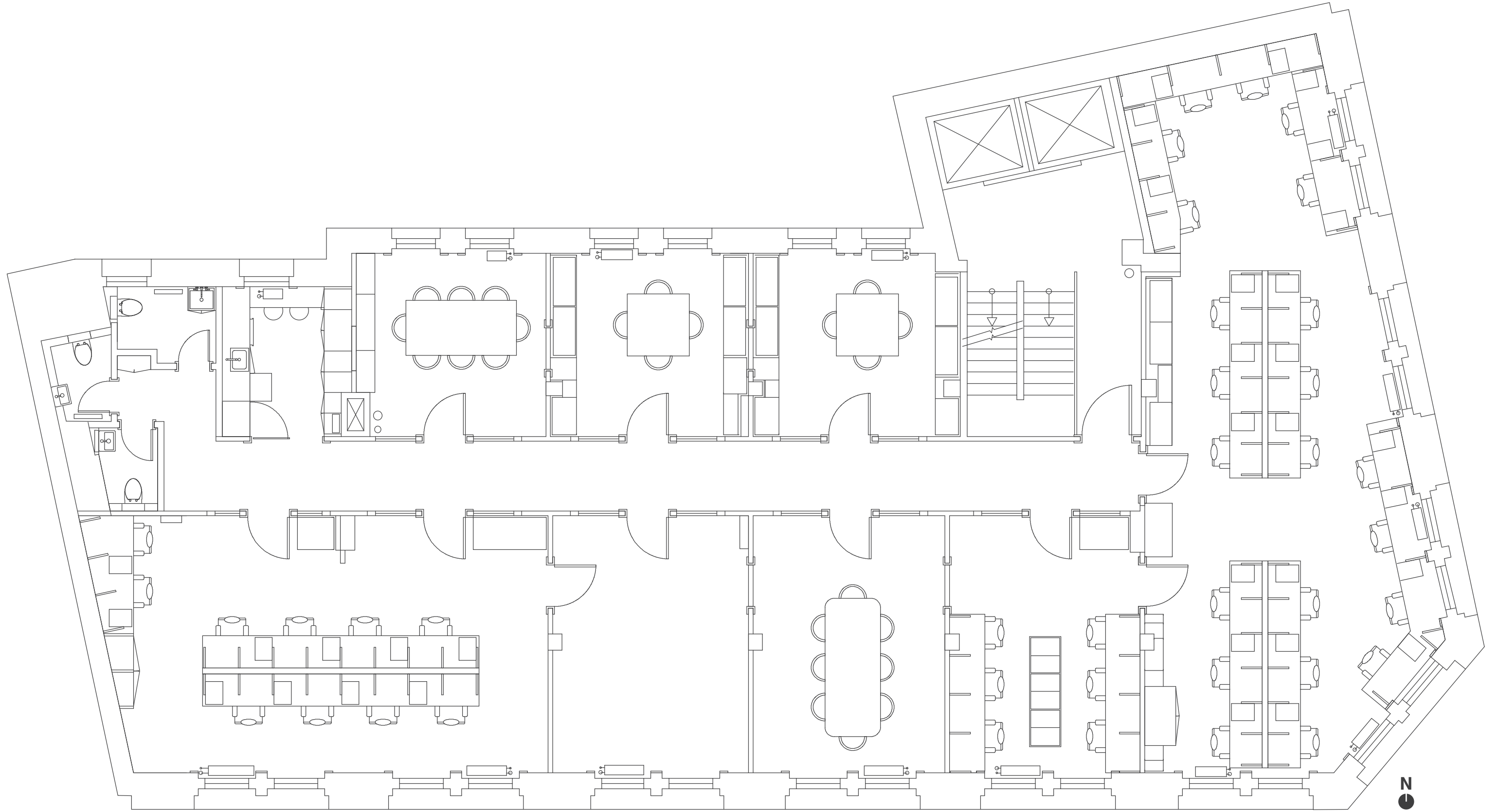

Floor 5
6,255 SF
13' Ceiling

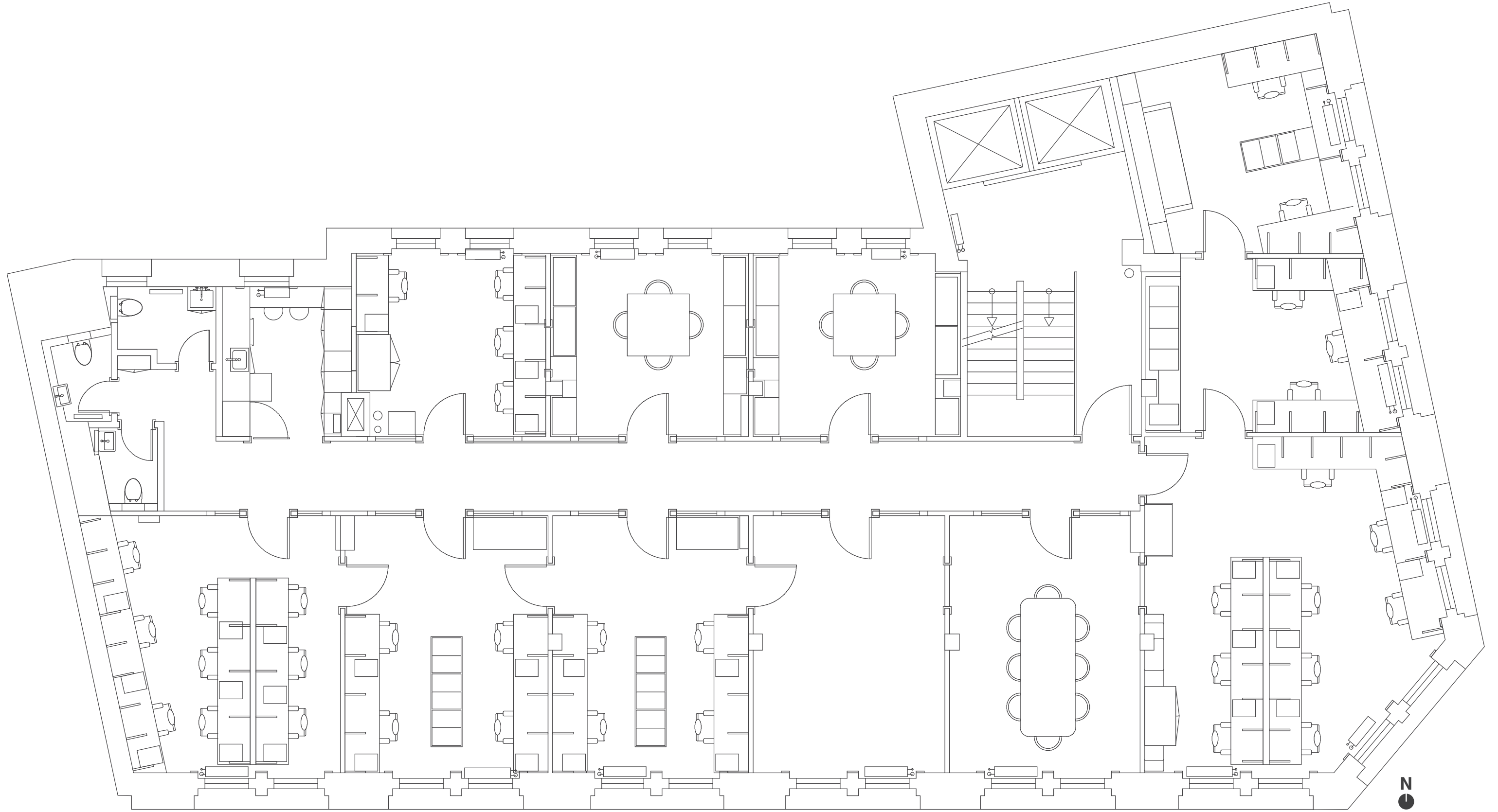

Floor 6
6,255 SF
12'-3" Ceiling

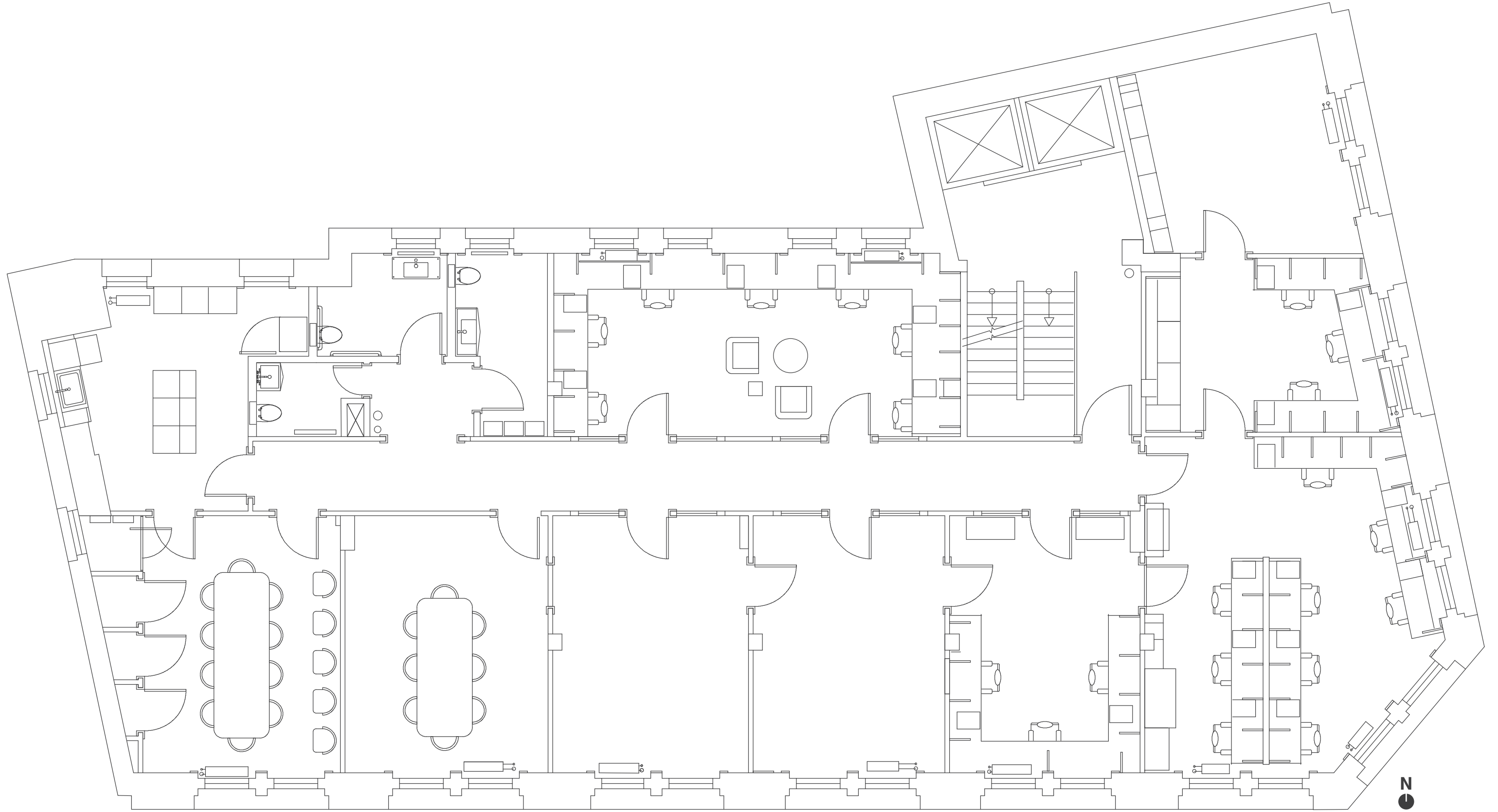

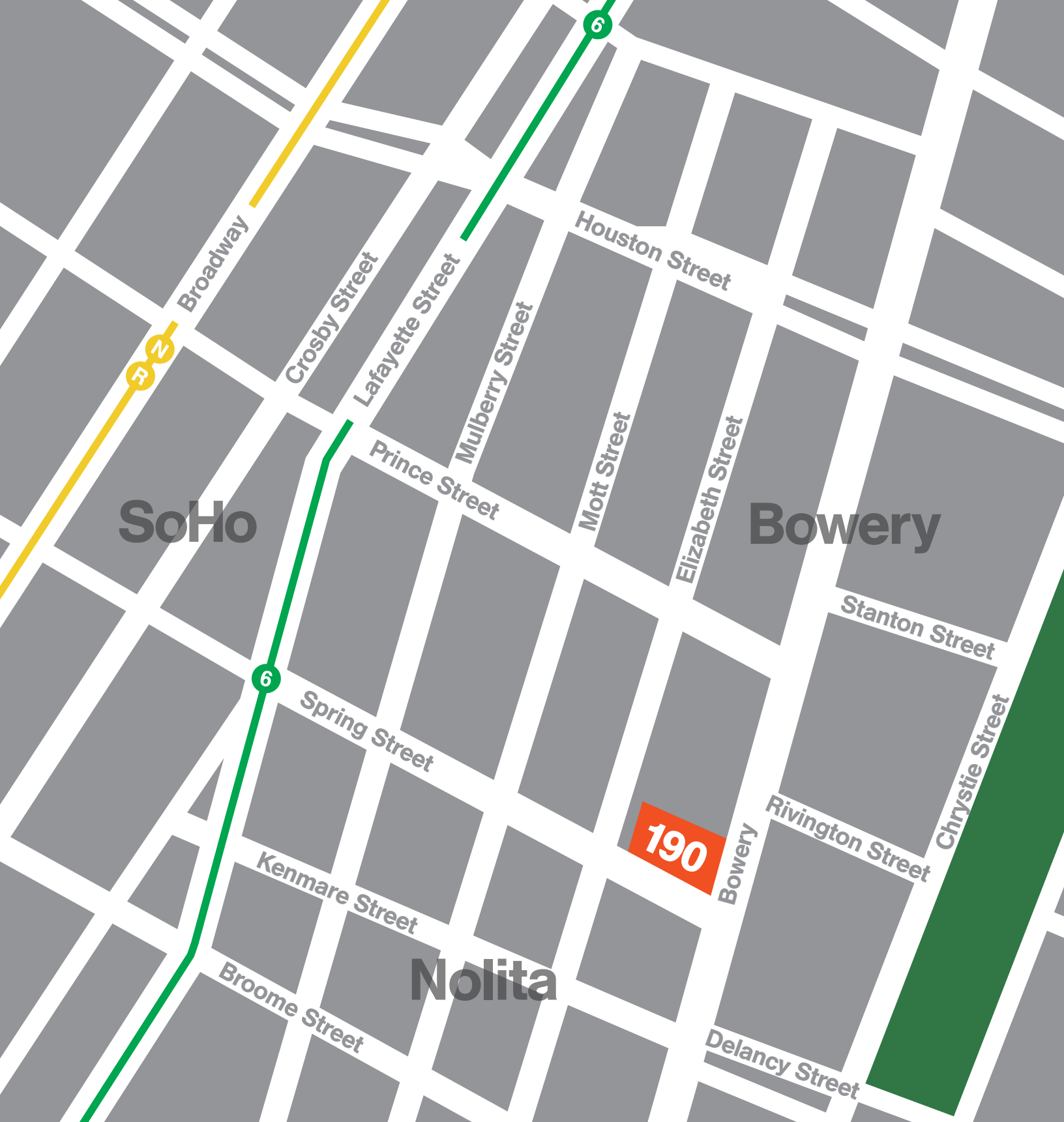

SoHo

Bowery

Nolita

190

RFR

190Bowery.com
rfrspace.com
@rfrrealty

AJ Camhi
acamhi@rfr.com
t. 212 308 1000

Rob Weller
rweiler@rfr.com
t. 646 277 9254

Ryan Silverman
rsilverman@rfr.com
t. 212 509 9075